

## Product Information Sheet

# 24V 6A and 12A Battery Chargers



### Overview

These battery chargers are ideally suited for PA systems and other equipment requiring battery backup. The design incorporates a two stage high voltage SCR controlled charging circuit, providing protection against high voltage power line transients. Two stage battery charging minimises the risk of sulphation of the battery plates thus extending battery life. Simple single stage float charging results in the battery plates eventually sulphating which greatly reduces battery capacity and life (typically this type of charging only yields around 85% of rated battery capacity per charge cycle).

The intelligent electronic circuitry includes protection against reverse battery polarity and charger output short circuiting. In addition it will not start up if connected to a 12V battery. In the event of the 240V mains power either failing or being switched off, the charger automatically isolates the battery thus preventing the battery from discharging back through the charger. This auto disconnect feature is important since, if power is disconnected from the charger for a considerable time, the batteries may discharge beyond recovery. The circuit ensures that full charge is reached quickly to minimise gassing of the electrolyte which can greatly reduce battery life and performance, especially with sealed lead acid batteries. The power and sensing circuits are "opto coupler isolated" ensuring optimum safety by preventing mains generated power transients being induced into the sensing circuitry

When mains is applied either initially or after mains failure, the charger automatically goes into boost charge mode. Once the boost voltage is reached it switches back to trickle charge.

### Operation

#### Normal mains power operation:

With 240V mains power available, the charger connects directly to the batteries via the internal relays.

#### Mains failure:

When mains fails the internal relay disconnects the charging circuit from the battery and connects it to the external load. This way the load is powered from the battery. In this mode the charger has a low battery cut off to ensure the battery is not discharged to a dangerous level causing permanent damage.

#### Important Notes:

1. Do not connect any load other than the batteries to the battery terminals. Failure to do this will cause incorrect charging of the battery.
2. For accurate battery terminal voltage you must connect a separate cable from the battery terminals to the battery voltage terminals on the charger.
3. During charging, the charger will emit a buzzing or humming sound. During boost charge this will be louder and more prominent than during trickle charge. This is normal and is due to the current being drawn from the mains transformer.
4. When using 2 x 12V or 4 x 6V batteries in series (which is common practice) to form a 24V battery you must equalise them. This is done by initially connecting them in parallel overnight (10-12 hours minimum) prior to connecting them to the charger. This ensures that the batteries are at or as close as possible to the same terminal voltage. Failure to do this can cause a severe imbalance in the charging of the batteries, some could be overcharged whilst the others undercharged causing permanent damage.
5. The battery voltage terminals must be connected or the charger **will not** power up as this also controls the low battery cut off.

### Features

- Short circuit protection
- Electronic reverse polarity protection
- 2 stage charging
- Automatic switching from boost and float voltages
- Precision control of boost and float voltage settings
- Digital battery voltage display
- Charging status indicator
- End of charge (battery ready) indicator
- 2U 19" rack mount chassis
- 2 year warranty
- Suits sealed, vented lead acid and gel batteries
- Low battery cut off
- 2 switched 50A outputs
- Australian designed and manufactured

# Battery and Load Circuit Configuration

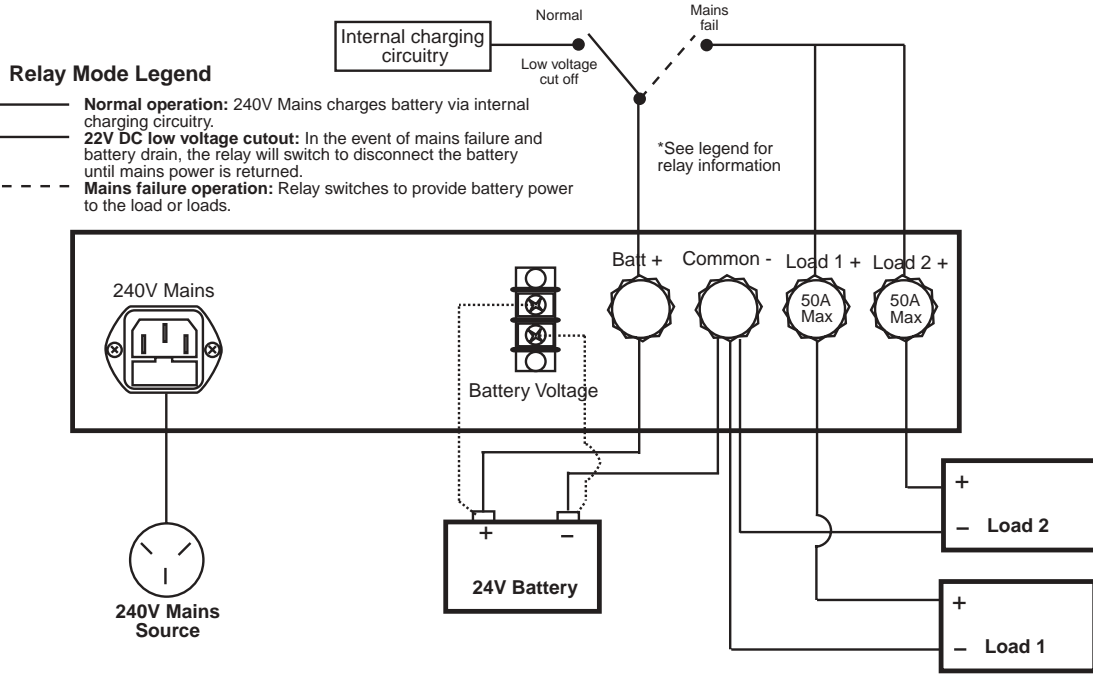

## Connecting batteries in series

It is common practice to connect 6V or 12V batteries in series to create a 24V battery source.

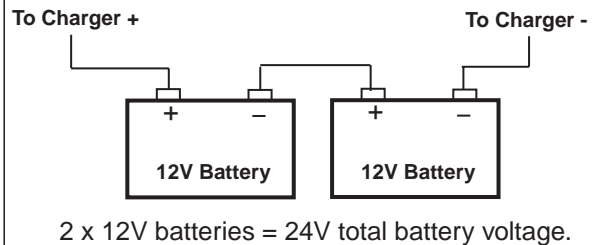
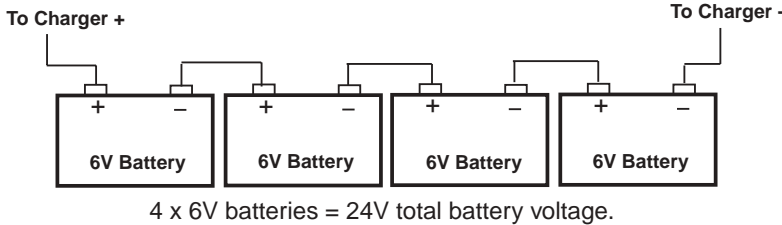

## Equalising batteries

Connect in parallel overnight (10-12 hours minimum) prior to connecting them to the charger. Failure to do this can cause a severe imbalance in the charging of the batteries causing permanent damage.

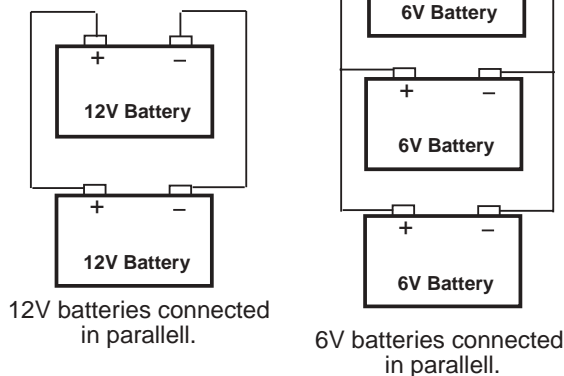

## Typical charge times

Charging time is dependent on the ampere hour rating of the battery and its condition of charge. Typical charge times for fully discharged batteries are listed below,

A 1607		A 1613	
24AH	6Hrs	60AH	8Hrs
40AH	10Hrs	80AH	10Hrs
		100AH	12Hrs
		120AH	14Hrs

## Calculating battery size for PA systems

$$\text{Battery Size} = \frac{\text{Total amplifier power in watts}}{\text{Volts}} \times 1.5 = \text{Required amps for 1 hour}$$

$$\text{500W amplifier Battery Size} = \frac{500}{24} \times 1.5 = 31.25\text{AH}$$

Therefore a 40AH battery would be suitable. Please note: This calculation assumes 100% duty cycle at full power output into full rated load.

## Specifications

Input voltage: .....240V AC 50Hz  
 Boost voltage: .....29.4V DC  
 Float voltage: .....27.6V DC  
 Dimensions: ..≈ 483W x 330D x 88H mm  
 Weight: .....A 1607 ≈ 8kg  
 .....A 1613 ≈ 9kg  
 \* Specifications may change without notice.