

Perth (Head Office)

174 Roe Street
Perth WA 6000

Sydney

15 Short Street
Auburn NSW 2144

Melbourne

891 Princes Highway
Springvale VIC 3171

International

Phone: 61 8 9428 2188
Fax: 61 8 9428 2187

Australia-Wide Sales Hotline

Phone: 1300 797 007 Fax: 1300 789 777

Order Online

www.altronics.com.au

Product Specification Sheet

Part No	Description	Supplier Ordering Info
M 0222	TRANS MINI DRIVER 3KCT/3K	YUAN CHIANG EI-16 MQ1K ROHS

TRANSFORMER SPECIFICATION

1 DESCRIPTION: *1PT* TRANSFORMER EI-1605 PARTS NO. *MO 222*

2 ELECTRICAL CHARACTERISTICS:

- 1.) Impedance ratio: (1-3) 3k ohm: (5-6) 3k ohm: () ohm
- 2.) Impedance Variation: $\pm 1.5\%$ at (KHZ / V
- 3.) Open Impedance: Over 4.5K ohm at / Khz with secondary open circuit.
- 4.) D.C. Resistance: (1-3) 220 ohm $\pm 10\%$
 (5-6) 270 ohm $\pm 10\%$
 () ohm $\pm \%$
- 5.) Inductance: (1-3) 1.6 H 0 mA. AC $\pm 1.5\%$ / KHZ / V
 (5-6) 1.6 H 0 mA. AC $\pm 1.5\%$ / KHZ / V
 () H mA. AC $\pm \%$ KHZ V
- 6.) Frequency Response: Less than ± 7.5 db 300 HZ ~ 3 KHZ (for / db at / KHZ)
- 7.) Center tap unbalance: Less than $\pm \%$
- 8.) Insulation: More than 100 Mega ohm 500 V.DC
- 9.) Break down: 100 V hipot for / minute. (AC)
- 10.) Insulation Resistance: After exposure for 24 Hours to moist air At $^{\circ}\text{C}$ Relative humidity $\%$. Not Less than Mega ohm V.DC & satisfied (9)
- 11.) Strain Relief: Not Less than lbs nor more than lbs.
- 12.) Polarity: () and () Short. () () have opposite Polarity

3. WAXING: VACUUM IMPREGNATED

4. DIMENSIONS & CONSTRUCTIONS: (m/m)

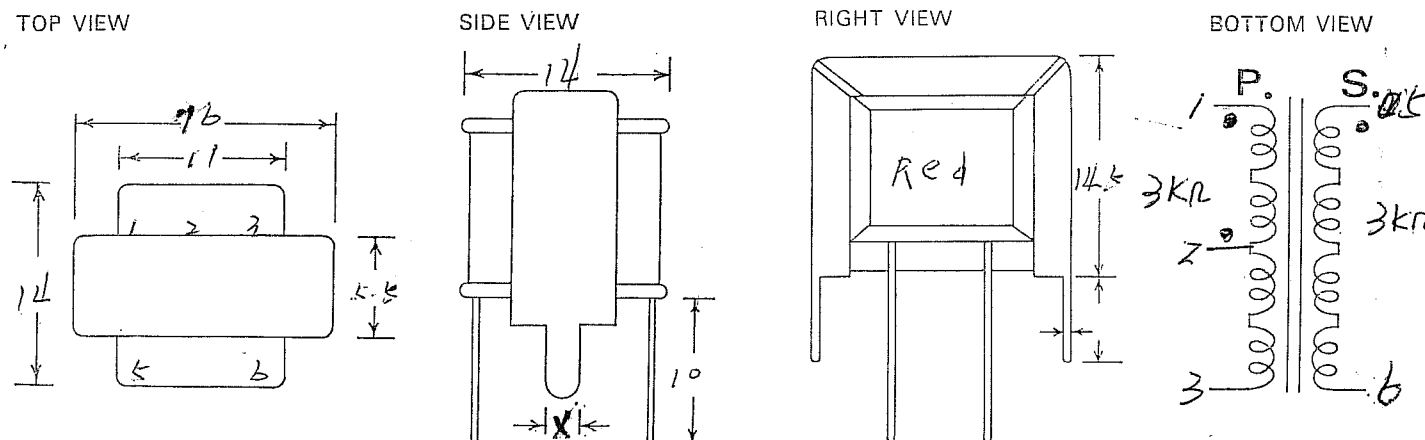

DDrawing By	Approved By <i>徐晓强</i>	YUAN CHIANG ELECTRICS IND CO., LTD.	Customer <i>明訊</i>	Date <i>77.8.29</i>
			Drawing NO:	